

# FM10

## 10.4" Intel Atom® E3845 Windows Vehicle Mounted Computer



### KEY FEATURES

- Intel® Quad Core Atom® E3845 Processor
- 10.4" 1024 x 768 Panel with anti-scratch resistive touch screen
- Field replaceable front panel to reduce service costs
- Magnesium alloy housing
- IP65 waterproof and dustproof
- Wide range operating temperature

CE FCC IC



PTCRB™



### SPECIFICATIONS

Display	
<b>Resolution</b>	1024x768
<b>Contrast Ratio</b>	1200:1
<b>View Angles</b>	88,88,88,88
<b>Touch Mode</b>	With Stylus Support
<b>Size</b>	10.4 inches
<b>Panel Brightness</b>	400 nits 800 nits(Optional)
<b>Type</b>	Resistive Touch
System Specification	
<b>Processor</b>	Intel Quad-Core Atom E3845 Processor , 1.91 GHz
<b>Storage</b>	64GB M.2 SSD 128GB M.2 SSD (Optional) 256GB M.2 SSD (Optional)
<b>WLAN</b>	802.11 a/b/g/n/ac mode
<b>WWAN</b>	4G/LTE (Optional)
<b>Sensors</b>	G-Sensor, Light Sensor ,Temp Sensor
<b>Memory</b>	4GB SODIMM DDR3L-1600 8GB SODIMM DDR3L-1600 (Optional)
<b>Operating System</b>	Windows 10 IoT Enterprise Windows Embedded 8.1 Industry Pro (Optional) Windows 7 Professional for Embedded System (Optional) Windows Embedded Standard 7 (Optional)
<b>BT</b>	BT Support
<b>GNSS</b>	GPS/AGPS
Camera	
<b>Front Camera</b>	2MP Camera
Environment	
<b>Operating Humidity</b>	5% to 90% RH, Non-Condensing
<b>Storage Temperature</b>	-30°C to 60°C
<b>Vibration</b>	MIL-STD-810G Method 514.6 Procedure I
<b>Impact</b>	Support EN62262 IK70 Rating
<b>Operating Temperature</b>	-20°C to 60°C AC Mode: -20°C to 50°C (-4°F to 122°F) Batter Mode: -10°C to 50°C (14°F to 122°F) with Optional Heater: -30°C to 50°C (-22°F to 122°F)
<b>Shock</b>	MIL-STD-810G Method 516.6 Procedure I, 30 g for 18 ms
<b>IP rating</b>	IP65 Certified, Waterproof and Dustproof
<b>ESD</b>	Compliant with EN 61000-4-2, enhanced ESD to ±12kV direct & ±15kV air
Certification	
<b>Certification</b>	CE, FCC, UL60950-1, EN60950-1, PTCRB, FCC (Electromagnetic Emissions), IC (ICES-003)

Control			
<b>Button</b>	1 x Power Button, 6 x Function Button (Programmable Function Key Configured by Winset)		
IO Ports			
<b>USB Port</b>	1 x USB 3.0(Tablet) 1 x DB9 Connector for 2 x USB 2.0 Port(Docking)	<b>Serial Port</b>	2 x COM Port(Docking)
<b>SD Card Slot</b>	1 x Micro SD Card Slot(Tablet)	<b>SIM Card Slot</b>	1 x SIM Card Slot(Tablet)
<b>Audio</b>	2 x Speaker(Docking) 1 x CANBus or 1 x Audio(Docking)	<b>LAN</b>	1 x Gigabit LAN port(Docking)
<b>Indicator</b>	4 x LED Indicator (Wi-Fi, BT, UPS battery, HDD, Screen Blanking, Heater)		
Mechanical			
<b>Dimension</b>	Tablet: 268 x 214 x 35 mm (10.6 x 8.42 x 1.37 inches) Docking: 202 x 245 x 52 mm (7.9 x 9.6 x 2.04 inches)	<b>Weight</b>	Tablet 1.7 kg (3.75 lbs) Docking 1.6 kg (3.53 lbs)
<b>Mounting</b>	RAM Mount/ VESA Mount	<b>Cooling System</b>	Fanless Design
<b>Housing</b>	Magnesium alloy housing		
Security Function			
<b>SOTI MobiControl</b>	SOTI MobiControl Compliance		
Accessory			
<b>Accessory</b>	5 m Power Cable Fuse Kit cable 0.3 m USB Cable 0.15 m Power Converter Cable Wi-Fi Antenna x 1 Quick Start Guide Driver CD 84W Adapter with Power Cable External Antenna Fixing Bracket	<b>Optional Accessory</b>	2 m DC Jack Power Cable (Optional) 1.2 M 120 Watt Adapter (For Heater Model) (Optional) 4.2 m Adapter with Power Cable (Optional) 1.8 m RS232 Cable (Optional) 0.3 m Audio Cable (Optional) 1.8 m CAN BUS Y Cable (Optional) 2 m IP65 LAN Cable (Optional) Wi-Fi Antenna x 1 (Optional) 15A, 250V, VDA Type Fuses (Optional) Spare Key for Vehicle Dock (Optional) DC 12C/ 2A Output UHF Fixed Reader (Optional) GPS & LTE 2M Combo Antenna(VM240) (Optional) GPS & LTE 5M Combo Antenna (VM9C) (Optional) GPS & LTE & Wi-Fi Magnetic (Optional) Combo Antenna (VM10S) (Optional) Mounting Kit 1 No Drill (Optional) Mounting Kit 2 Drill (Optional) Mounting Kit 3 Keyboard Mounting (Optional) Stylus Kit + Screw (Optional)
Power			
<b>Battery</b>	7.6V UPS Battery (2S1P) Minimum 30 minutes	<b>Power Rating</b>	Docking: 10V-60V with ignition control  Tablet: 12V DC In

## DIMENSIONS UNIT:MM

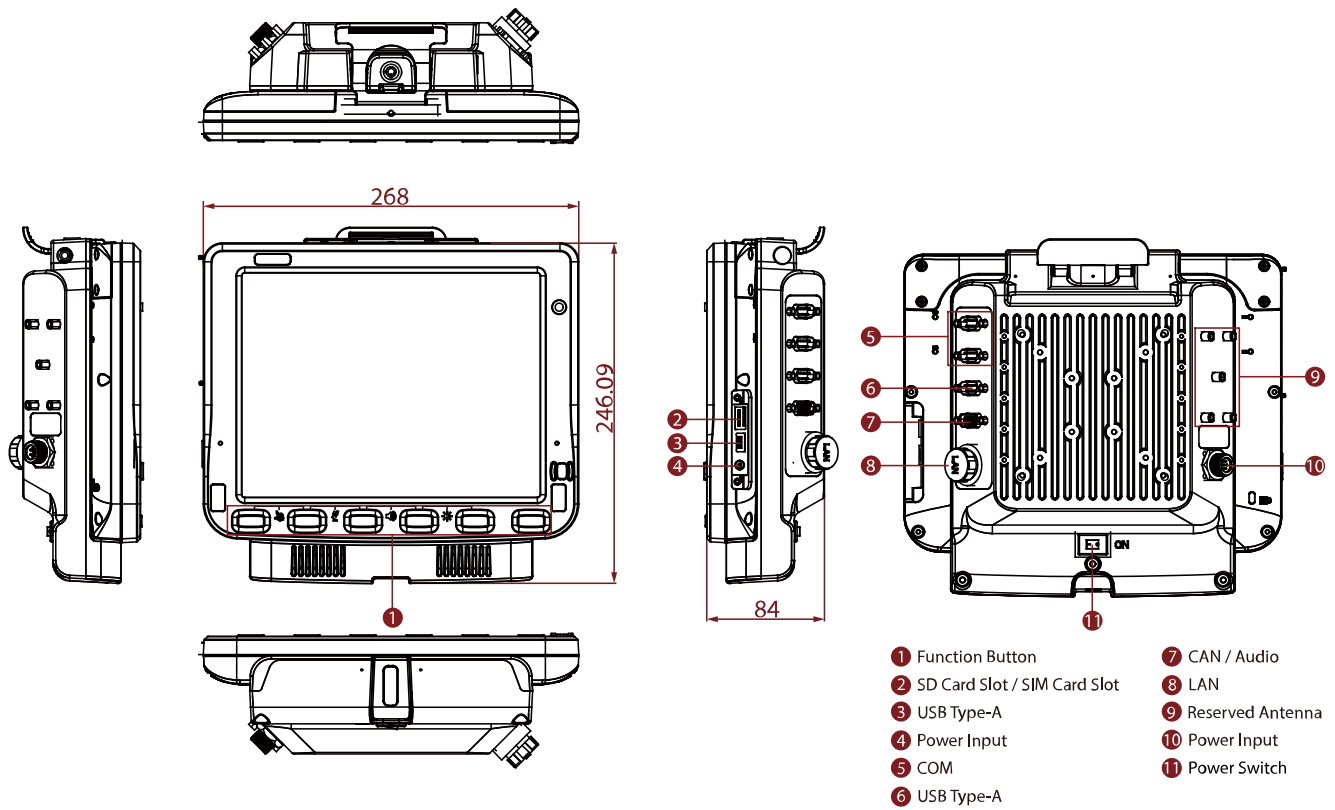

## NOTE

1. Total usable memory will be less dependent upon actual system configuration.
2. SOTI is available upon request.
3. Length measurements do not include protrusions. Weight varies with options.
4. Measured at dimming LCD brightness. Varies depending on the usage conditions, or when an external device is attached.
5. Accessories may vary depending on your configuration.
6. This is a simplified drawing and some components are not marked in detail.
7. The product shown in this datasheet is a standard model. For diagrams that contain customized or optional I/O, please contact the Winmate Sales Team for more information.